

# Extraction of Fish Oil by Fractionation through Supercritical Carbon Dioxide

R. Davarnejad, K. M. Kassim, A. Zainal, and Suhairi A. Sata\*

School of Chemical Engineering, Engineering Campus, Universiti Sains Malaysia, 14300 Nibong Tebal, Penang, Malaysia

In the present research, the solubility of fish oil in supercritical carbon dioxide was studied at temperatures of (40, 50, 60, and 70) °C and pressures of (13.6, 20.4, and 27.2) MPa. The fractionated fish oil samples collected were then esterified using methanol (with sodium methoxide catalyst). The samples were analyzed by GC to determine the amount of four fatty acid methyl ester (FAME) components extracted, namely, methyl palmitate, methyl oleate, methyl EPA (5,8,11,14,17-eicosapentanoate), and methyl DHA (4,7,10,13,16,19-docosahexenoate). The experimental results showed that the highest solubility of the fish oil (0.921 g of oil/100 g of CO<sub>2</sub>) was obtained at optimum conditions of 40 °C and 27.2 MPa. The solubility of fish oil in supercritical carbon dioxide was found to be higher at lower temperature and at lower fractionation time. Furthermore, the average yield obtained for the combined total of the four FAME components was 66 %. Methyl palmitate recorded the highest value of 30.5 % at extraction conditions of 50 °C and 13.6 MPa. Methyl EPA has the lowest value of 3.24 %.

## Introduction

Seventy-five percent of the earth is covered with water. Further, it hosts various forms of aquatic organisms, most of which can be valuable sources of protein and natural products such as oils. The quality of the oils can be substantially increased by processing to recover certain fractions, such as squalene from shark liver oil, or removing undesirable components, such as fatty acids, off-aromas, and peroxides. The standard industrial processing methods include molecular distillation, high vacuum distillation, and high temperature distillation.<sup>1</sup>

Countercurrent near-critical fluid extraction is a potential alternative to these methods. Some works have already been carried out on the extraction of squalene from shark liver oil,<sup>2,3</sup> vitamin A from fish and shark liver oils,<sup>4</sup> and the fractionation of fatty acid methyl esters from fish oils.<sup>5,6</sup> Packed column fractionation of synthetic polyunsaturated glycerides derived from fish oils has also been reported using supercritical CO<sub>2</sub> and ethanol mixtures.<sup>7</sup>

Interest in  $\omega$ -3 fatty acids (e.g., 4,7,10,13,16,19-docosahexenoate (C22:6) or DHA and 5,8,11,14,17-eicosapentanoate (C20:5) or EPA) started several years ago.<sup>8</sup> Currently, there is a lot of scientific literature supporting their positive effects on human health, as they can intervene in the prevention and modulation of certain diseases.<sup>8</sup> Medical research has shown that  $\omega$ -3's can reduce the risk of heart disease and high blood pressure, prevent blood clots, protect against cancer, and even alleviate depression.<sup>9–11</sup> DHA, found in the cell membrane of various tissues throughout the body, can represent about 36 % of its total fatty acid content. It is also found in high concentrations especially in the retina, brain, and sperm.<sup>12</sup> Furthermore, with regard to cholesterol prevention, a higher concentration of EPA is required in comparison with DHA, while the opposite relative concentration (i.e., DHA > EPA) is required during pregnancy or for retina protection.<sup>9,13</sup>

Eissenbach<sup>14</sup> and Nilsson<sup>15,16</sup> studied the fatty acid ethyl ester (FAEE) behavior in supercritical carbon dioxide, using batch-continuous equipment at high temperatures up to 100 °C.<sup>6</sup>

Some researchers have shown that it is possible to obtain concentrations of heavy components (ethyl esters of C20 and C22 fatty acids) greater than 95 % by weight, together with high yields, operating a continuous countercurrent process in a column provided with an external reflux of extract and by using values of solvent to feed ratio in the range 60 to 130.<sup>17</sup>

Phase equilibrium measurements of ethyl EPA and ethyl DHA and modeling of ethyl EPA and ethyl DHA in supercritical CO<sub>2</sub> were also reported by Jaubert et al.,<sup>18</sup> whereby a high pressure, variable-volume visual cell was used to perform static measurements of phase equilibria of EPA and DHA. They obtained FAEE with purity of over 97 %, while Bharath et al.<sup>19</sup> obtained FAEE with a maximum purity of 90 %.

Other researchers studied phase equilibria of fish oil fatty acid ethyl esters in sub- and supercritical CO<sub>2</sub>. They reported high selectivity and low solubility at low operating pressure. On the contrary, they found low selectivity and high solubility at high operating pressure. More than 95 % of the natural FAEE mixtures was identified.<sup>20</sup>

Higashi et al.<sup>21</sup> enriched ethyl EPA and DHA from 12 % to 93 % and 13 % to 82 %, respectively, using a supercritical extraction process.

Phase equilibria of a model mixture of C16 and C18 fatty acid methyl esters in supercritical carbon dioxide were studied by van Gaver.<sup>22</sup> This was developed in detail by Brunner.<sup>5</sup> He concluded that the shorter chain fatty acid esters and unsaturated esters tend to enrich in the gas phase. Due to this, the optimized conditions for enrichment of unsaturated free fatty acids according to carbon chain length were loading of (3 to 5) wt % (pressure about 14 MPa) at a temperature of 60 °C. The separation factor for the separation of C16 and C18 fatty acid methyl esters at the mentioned conditions was 1.3 to 1.4.<sup>5</sup>

Fractionation of fish oil and polyunsaturated  $\omega$ -3 fatty acid concentration from it with supercritical CO<sub>2</sub> was studied over the temperature range (301 to 323) K and pressure range (7.8 to 29.4) MPa by Corrêa et al.<sup>23</sup> According to this study, the

\* Corresponding author. E-mail address: chhairi@eng.usm.my. Tel.: +60-45996401. Fax: +60-45941013.

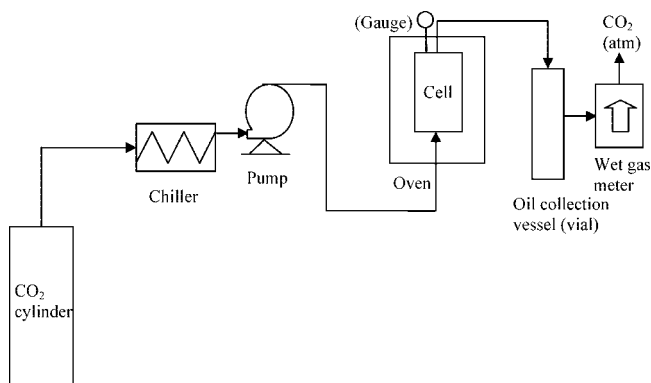

Figure 1. Supercritical fluid extraction unit.

best operational conditions to fractionate the fish oil were 7.8 MPa and 301.15 K, although in all the conditions analyzed, eicosapentaenoic acid (EPA) could not be fractionalized.

A semicontinuous fractionation process of fish oil ethyl esters was studied over the temperature range (42 to 70) °C and at pressure range (10.1 to 17.2) MPa by Gironi and Maschietti.<sup>24</sup> According to this study, the optimal operating conditions for solvent density were found around (570 to 595) kg·m<sup>-3</sup>. Furthermore, better results were obtained at temperature 343.15 K and at pressure 16.7 MPa among possible pressure–temperature couples that led to the mentioned range of solvent density.

There have been several studies of fish oil extraction and fractionation of fatty acid ethyl esters (FAEE) in the field study of vapor–liquid equilibria,<sup>25–28</sup> however, there are few studies on fatty acid methyl esters.

In this study, the solubility of fish oil in supercritical carbon dioxide was studied at temperatures of (40, 50, 60, and 70) °C and pressures of (13.6, 20.4, and 27.2) MPa. For this purpose, supercritical fluid extraction of fish oil by CO<sub>2</sub> was achieved, and then the samples from the final stage were fractionated by methanol esterification. So, two methods containing supercritical extraction and methanol esterification were studied together.

## Experimental

**Materials.** Fish oil from Menhaden was provided by Sigma-Aldrich Sdn Bhd. Liquefied carbon dioxide (99.99 %) was purchased from the Malaysian Oxygen Bhd. A sodium methoxide (0.5 molar) solution in methanol (99 %) was purchased from Sigma-Aldrich Sdn Bhd. Standard FAMES (in standard grade) were purchased from Sigma-Aldrich Sdn Bhd.

**Apparatus and Method.** The setup for the extraction process is shown in Figure 1. It consists of a pump (American Lewa, Holistic, Massachusetts, USA) with a maximum capacity of 69.0 MPa, an oven (C.C.S Instrument System), a chiller (Yin Deer, B/L-730) with a minimum temperature of –5 °C, and a 50 cm<sup>3</sup> extraction cell (Keystone), with 13 mm diameter and 320 mm height, and a wet gas meter (WNK-1A; Sinagawa Corp., Tokyo, Japan).

The extractor was equipped with a pressure gauge in psi unit which was able to measure low-pressure increments. The obtained pressures from the gauge were converted to MPa units up to one decimal point. This apparatus has been applied by other researchers, and reliability of the experimental data has already been confirmed.<sup>29,30</sup>

The experiments were performed at a mild temperature range of (40 to 70) °C because fish oil is rather involatile and thermally sensitive.<sup>31</sup>

The experimental data were produced based on the average of the two repeat runs performed for each data point. The repeat

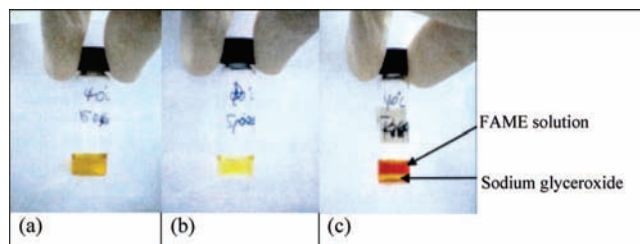

Figure 2. (a) Pure fish oil before supercritical extraction is golden in color. (b) Extracted fish oil sample at pressure 13.6 MPa and temperature 40 °C is yellowish in color. (c) Liquid methyl ester (is orange in color) and precipitated layer of sodium.

runs ensured that the experiments could be repeated within an experimental error of  $\pm 2$  %.

Supercritical extraction of free fatty acids from fish oil using carbon dioxide was started when CO<sub>2</sub> was pumped into the heated extraction cell loaded with approximately 3 cm<sup>3</sup> of fish oil. The operating conditions for the supercritical extraction process were set at pressures of (13.6, 20.4, and 27.2) MPa and temperatures of (40, 50, 60, and 70) °C. Four fractions of fish oil (palmitate, oleate, EPA, and DHA) were extracted over a 40 min duration corresponding to the extraction conditions, and each fractionation took about 10 min to complete. Glass beads were placed with the fish oil in the cell to provide a surface for better extraction of the fish oil. The extracted samples were collected in 3.5 mL screw vials (S. Murray, U.K.). The amount of fish oil extracted was determined by weighing the sample vials before and after the sampling. The solubility determination was based on the amount of CO<sub>2</sub> consumed via wet gas meter and also determination of the CO<sub>2</sub> density in the fish oil.

The free fatty acids from fish oil which were fractionated via the supercritical fluid extraction apparatus were converted to methyl esters by chemical esterification with 0.5 M sodium methoxide in methanol in a shaker at room temperature for a few minutes. Thereafter, a sample comprising two phases was obtained. Fatty acid methyl esters (FAMES) which presented in the upper phase were extracted and injected into a gas chromatograph (model: HP 5890 series II) which was equipped with a OMEGA WAX 250 capillary column with dimensions of 30 m length  $\times$  0.25 mm internal diameter, 0.25  $\mu$ m film thickness, and a flame ionization detector. The oven temperature was set at 215 °C in isothermal conditions. Helium was used as the carrier gas at a flow rate of 30 cm<sup>3</sup>·sec<sup>-1</sup>. Figure 2a–c illustrates the variations of fish oil from the pure to extract via supercritical CO<sub>2</sub> (at 13.6 MPa and 40 °C) and finally esterified for GC analysis. According to the GC analysis of FAME components, it is observed that the FAME with the lowest molecular weight, i.e., methyl palmitate, was eluted first (at a retention time of 5.53 min). Furthermore, the longest elution belonged to the largest molecular weight of methyl DHA (at a retention time of 24.45 min).

## Results and Discussion

The effect of pressure and fractionation time on fish oil solubility at different temperatures is shown in Figures 3 to 6. Figure 3 shows fish oil solubility (g of oil/100 g of CO<sub>2</sub>) against pressure at various fractionation times at 40 °C. It shows the fractionation at 20 min has the highest values of solubility averaging 0.86 g of oil/100 g of CO<sub>2</sub> and at the highest pressure. It seems that at low temperatures (40 °C) the fractionation time has no significant effect on solubility at low and high pressures ((13.6 and 27.2) MPa), while it has a significant effect on solubility at a middle pressure (20.4 MPa). At a middle pressure,

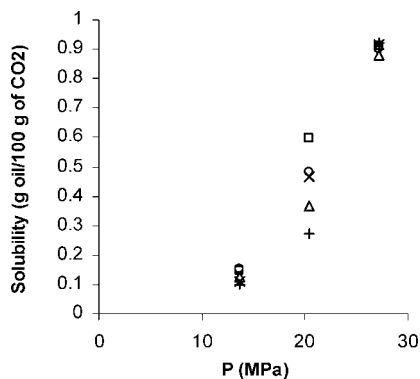

**Figure 3.** Solubility of fish oil in carbon dioxide against pressure at elevated fractionation times at 40 °C. O, fractionation time 10 min; □, fractionation time 20 min; Δ, fractionation time 30 min; ×, fractionation time 40 min; +, fractionation time 50 min.

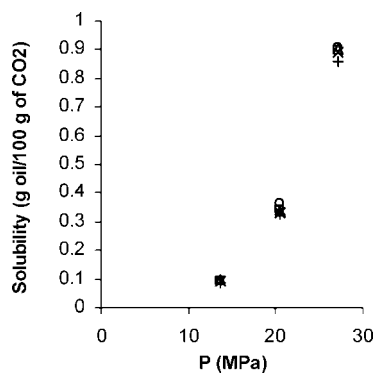

**Figure 4.** Solubility of fish oil in carbon dioxide against pressure at elevated fractionation times at 50 °C. O, fractionation time 10 min; □, fractionation time 20 min; Δ, fractionation time 30 min; ×, fractionation time 40 min; +, fractionation time 50 min.

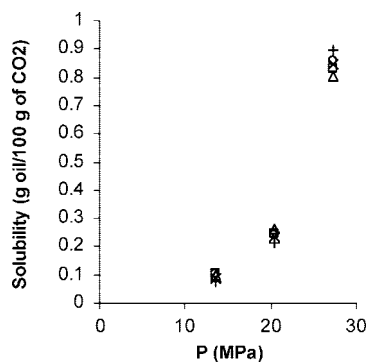
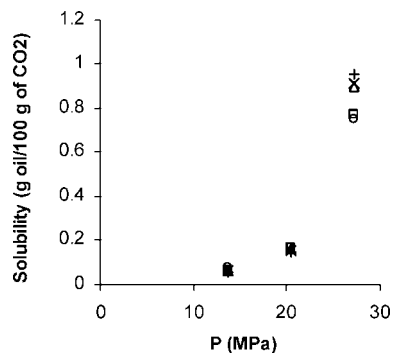

**Figure 5.** Solubility of fish oil in carbon dioxide against pressure at elevated fractionation times at 60 °C. O, fractionation time 10 min; □, fractionation time 20 min; Δ, fractionation time 30 min; ×, fractionation time 40 min; +, fractionation time 50 min.

a low solubility was observed at the highest fractionation time (50 min), while fractionation at 20 min shows the highest solubility. The main cause of the highest solubility of fractionation at 20 min is due to the manual adjustments of the restrictor valve that could lead to improper fluctuations of the CO<sub>2</sub> intake.

Figure 4 shows fish oil solubility (g of oil/100 g of CO<sub>2</sub>) against pressure at various fractionation times at 50 °C. It shows that the solubilities at the same pressures and at the same fractionation times coincided together; however, a lower solubility was observed for a fractionation time of 50 min at highest pressure (27.2 MPa) in comparison with the other solubility points at the same pressure.

Figures 5 and 6 show fish oil solubility (g of oil/100 g of CO<sub>2</sub>) against pressure at various fractionation times at (60 and



**Figure 6.** Solubility of fish oil in carbon dioxide against pressure at elevated fractionation times at 70 °C. O, fractionation time 10 min; □, fractionation time 20 min; Δ, fractionation time 30 min; ×, fractionation time 40 min; +, fractionation time 50 min.

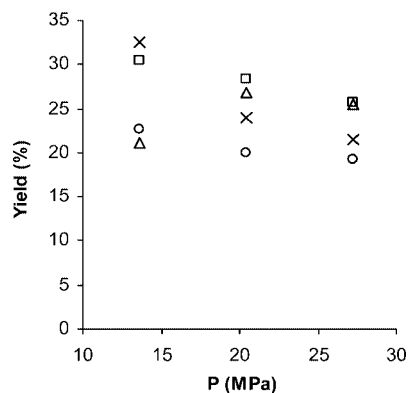
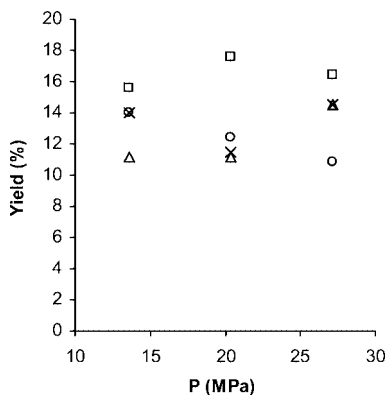

**Figure 7.** Yield percentage of extracted methyl palmitate at elevated pressure and temperature. O,  $T = 40$  °C; □,  $T = 50$  °C; Δ,  $T = 60$  °C; ×,  $T = 70$  °C.

70) °C. They show that the highest solubilities were observed at maximum pressure (27.2 MPa) and at maximum fractionation time (50 min). It seems that at temperatures more than 40 °C the fractionation time has no significant effect on solubility at various constant pressures.

Furthermore, it is observed that at the lower temperature of 40 °C the solubility was higher than that of high temperature at 70 °C. A significant difference in solubility was observed at a pressure of 20.4 MPa with a difference of about 0.5 g of oil/100 g of CO<sub>2</sub>. Solubility also decreases with an increase in temperature. This is probably due to the solvent power of CO<sub>2</sub> which decreases with higher pressure and temperature. Temperature affects the vapor pressure and the intermolecular forces which determine the solubility of the fish oil in supercritical CO<sub>2</sub> mixtures.

Figure 7 shows the complete variation of methyl palmitate in its value of yield (amount of fish oil extracted at each fractionation/total amount of fish oil at each fractionation) at elevated temperature and pressure. It also shows that the highest yield of the extracted methyl palmitate was 32.57 % at a temperature of 70 °C and at a pressure of 13.6 MPa. Figure 8 shows the complete variation of methyl oleate in its value of yield at elevated temperatures and pressures. It also shows that the highest yield of the extracted methyl oleate was 17.35 % at a temperature of 50 °C and at a pressure of 20.4 MPa. Figure 9 shows the complete variation of methyl EPA in its value of yield at elevated temperature and pressure. It clearly shows that the highest yield of the extracted methyl EPA was 4.35 % at conditions similar to that of methyl oleate. Figure 10 shows the complete variation of methyl DHA in its value of yield at elevated temperature and pressure. Furthermore, it shows that



**Figure 8.** Yield percentage of extracted methyl oleate at elevated pressure and temperature. ○,  $T = 40\text{ }^{\circ}\text{C}$ ; □,  $T = 50\text{ }^{\circ}\text{C}$ ; △,  $T = 60\text{ }^{\circ}\text{C}$ ; ×,  $T = 70\text{ }^{\circ}\text{C}$ .

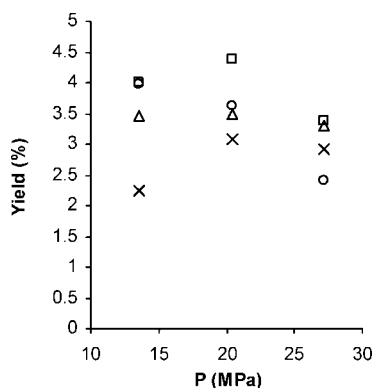

**Figure 9.** Yield percentage of extracted methyl EPA at elevated pressure and temperature. ○,  $T = 40\text{ }^{\circ}\text{C}$ ; □,  $T = 50\text{ }^{\circ}\text{C}$ ; △,  $T = 60\text{ }^{\circ}\text{C}$ ; ×,  $T = 70\text{ }^{\circ}\text{C}$ .

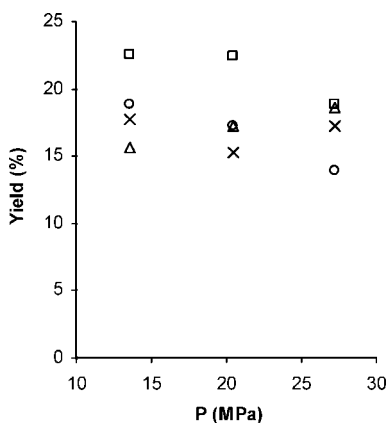

**Figure 10.** Yield percentage of extracted methyl DHA at elevated pressure and temperature. ○,  $T = 40\text{ }^{\circ}\text{C}$ ; □,  $T = 50\text{ }^{\circ}\text{C}$ ; △,  $T = 60\text{ }^{\circ}\text{C}$ ; ×,  $T = 70\text{ }^{\circ}\text{C}$ .

the highest yield of the extracted methyl DHA obtained was 24.25 % at conditions similar to that of methyl oleate and methyl EPA.

One common variation could be observed from these figures (Figures 8 to 10). The amount of component extracted of each of the FAMES (except methyl palmitate) has the highest amount of yield at a temperature of 50 °C.

## Conclusions

The solubility of fish oil using supercritical CO<sub>2</sub> was studied with pressures ranging from (13.6 to 27.2) MPa and temperature from (40 to 70) °C. The maximum solubility (0.921 g of oil/

100 g of CO<sub>2</sub>) was obtained at operating conditions of 40 °C and 27.2 MPa. Supercritical fluid extraction is very effective at moderately low temperature at which it limits oxidation, decomposition, and polymerization of the highly unsaturated FAME present in the pure Menhaden fish oil.

## Acknowledgment

Our real debt of gratitude goes to Dr. Hasnain Isa and Dr. Long Wei Sing who helped and guided us.

## Literature Cited

- (1) Catchpole, O. J.; Grey, J. B.; Noemark, K. A. Fractionation of fish oils using supercritical CO<sub>2</sub> and CO<sub>2</sub> + ethanol mixtures. *J. Supercrit. Fluids* **2000**, *19*, 25–37.
- (2) Catchpole, O. J.; von Kamp, J. C.; Grey, J. B. Extraction of Squalene from Shark Liver Oil in a Packed Column Using Supercritical CO<sub>2</sub>. In *Proceedings of the Fourth International Symposium on Supercritical Fluids*; Saito, S., Arai, K., Eds.; 1997; vol. A.
- (3) Catchpole, O. J.; von Kamp, J. C.; Grey, J. B. Extraction of squalene from shark liver oil in a packed column using supercritical carbon dioxide. *Ind. Eng. Chem. Res.* **1997**, *36*, 4318.
- (4) Passino, H. J. The soxhlet process. *Ind. Eng. Chem.* **1949**, *41*, 280.
- (5) Brunner, G. *Gas Extraction, An Introduction to Fundamentals of Supercritical Fluids and the Application to Separation Processes*; Springer: Berlin, 1994.
- (6) Nilsson, W. B. Supercritical Fluid Extraction and Fractionation of Fish Oils. In *Supercritical Fluid Technology in Oil and Lipid Chemistry*; King, J. W., List, G. R., Eds.; American Oil Chemists Society: IL, 1996.
- (7) Perrut, M.; Majewski, W.; Breivik, H. Purifying polyunsaturated fatty acid glycerides, World Patent. WO9832819, 1998.
- (8) Perretti, G.; Motori, A.; Bravi, E.; Favati, F.; Montanari, L.; Fantozzi, P. Supercritical carbon dioxide fractionation of fish oil fatty acid ethyl esters. *J. Supercrit. Fluids* **2007**, *40*, 349–353.
- (9) Shahar, E.; Folsom, A. R.; Melnick, S. L.; Tockman, M. S.; Comstock, G. W.; Gennaro, V.; Higgins, M. W.; Sorlie, P. D.; Ko, W. J.; Szklo, M. Dietary n-3 polyunsaturated fatty acids and smoking-related chronic obstructive pulmonary disease. *N. Engl. J. Med.* **1994**, *331*, 228–233.
- (10) Von Schacky, C.; Angerer, P.; Kothny, W.; Theisen, K.; Mudra, H. Effect of dietary omega-3 fatty acids on coronary atherosclerosis: a randomized, double-blind placebo-controlled trial. *Ann. Intern. Med.* **1999**, *130*, 554–562.
- (11) Gironi, F.; Maschietti, M. Separation of fish oils ethyl esters by means of supercritical carbon dioxide: Thermodynamic analysis and process modeling. *Chem. Eng. Sci.* **2006**, *61*, 5114–5126.
- (12) Connor, W. E. Importance of n-3 fatty acids in health and disease. *Am. J. Clin. Nutr.* **2000**, *71*, 171S–175S.
- (13) Maes, M.; Christophe, A.; Bosmans, E.; Lin, A.; Neels, H. In humans, serum polyunsaturated fatty acid levels predict the response of pro-inflammatory cytokines to psychological stress. *Biol. Psychiatry* **2000**, *47*, 910.
- (14) Eisenbach, W. Supercritical fluid extraction: a film demonstration. *Ber. Bunsen-Ges. Phys. Chem.* **1984**, *88*, 882–887.
- (15) Nilsson, W. B.; Gauglitz, E. J.; Hudson, J. K.; Stout, V. F.; Spinelli, J. Fractionation of menhaden oil ethyl esters using supercritical fluid CO<sub>2</sub>. *J. Am. Oil Chem. Soc.* **1988**, *65*, 109–117.
- (16) Nilsson, W. B.; Gauglitz, E. J.; Hudson, J. K. Supercritical fluid fractionation of fish oil esters using incremental pressure programming and a temperature gradient. *J. Am. Oil Chem. Soc.* **1989**, *66*, 1596–1600.
- (17) Riha, V.; Brunner, G. Separation of fish oil ethyl esters with supercritical carbon dioxide. *J. Supercrit. Fluids* **2000**, *17*, 55–64.
- (18) Jaubert, J. N.; Borg, P.; Coniglio, L.; Barth, D. Phase equilibrium measurements and modeling of EPA and DHA ethyl esters in supercritical carbon dioxide. *J. Supercrit. Fluids* **2001**, *20*, 145–155.
- (19) Bharath, R.; Yamane, S.; Inomata, H.; Adschiri, T. Phase equilibria of supercritical CO<sub>2</sub>-fatty oil component binary systems. *Fluid Phase Equilib.* **1993**, *83*, 183–192.
- (20) Staby, A.; Mollerup, J. M. Separation of constituents of fish oil using supercritical fluids: A review of experimental solubility, extraction and chromatographic data. *Fluid Phase Equilib.* **1993**, *91*, 349–386.
- (21) Higashi, H.; Iwai, Y.; Arai, Y. Solubilities and diffusion coefficients of high boiling compounds in supercritical CO<sub>2</sub>. *Chem. Eng. Sci.* **2001**, *56*, 3027–3044.
- (22) van Gaver, D. *Fractionatie van Vetzuuresters met Supercritische Extractie*; Dissertation, Universiteit Gent: Germany, 1992.

- (23) Corrêa, A. P. A.; Peixoto, C. A.; Gonçaves, L. A. G.; Cabral, F. A. Fractionation of fish oil with supercritical carbon dioxide. *J. Food Eng.* **2008**, *88*, 381–387.
- (24) Gironi, F.; Maschietti, M. Separation of fish oils ethyl esters by means of supercritical carbon dioxide: thermodynamic analysis and process modeling. *Chem. Eng. Sci.* **2006**, *61*, 5114–5126.
- (25) Bharath, R.; Inomata, H.; Arai, K.; Shoji, K.; Noguchi, Y. Vapor-liquid equilibria for binary mixtures of carbon dioxide and fatty acid ethyl esters. *Fluid Phase Equilib.* **1989**, *50*, 318–328.
- (26) Rizvi, S. S. H.; Yu, Z. R. and Bhaskar, A. R. *Fundamentals of processing with supercritical fluids. Supercritical fluid processing of food and biomaterials*; Blackie Academic & Professional, 1994.
- (27) Riha, V.; Bruuner, G. Phase equilibrium of fish oil ethyl esters with supercritical carbon dioxide. *J. Supercrit. Fluids* **1999**, *15*, 33–50.
- (28) Inomata, H.; Arai, K.; Shoji, K. Vapor-liquid equilibrium for binary mixtures of carbon dioxide and fatty acid ethyl esters. *Fluid Phase Equilib.* **1989**, *50*, 315–327.
- (29) Hassan, M. N.; Ab. Rahman, N. N.; Ibrahim, M. H.; Omar, A. K. M. Simple fractionation through the supercritical carbon dioxide extraction of palm kernel oil. *Sep. Purif. Technol.* **2000**, *19*, 113–120.
- (30) Nik Norulaini, N. A.; Md Zaidul, I. S.; Anuar, O.; Omar, A. K. M. Supercritical enhancement for separation of lauric acid and oleic acid in palm kernel oil (PKO). *Sep. Purif. Technol.* **2004**, *39*, 133–138.
- (31) Singh, P. Phase equilibrium studies in fish oil fatty acid methyl esters (FAME) with supercritical CO<sub>2</sub>. Master Thesis, Universiti Sains Malaysia, 2004.

Received for review April 19, 2008. Accepted June 27, 2008. This work was financially supported by the Ministry of Science, Technology and Innovations of Malaysia (IRPA grant No: 6012616).

JE800273C